



AST - 2 PENDANT MOUNT STROBE WARNING LIGHT

APPLICATIONS:

- to visually indicate warnings or hazards in high noise level areas where audible signals may not be heard
- to indicate the starting and stopping of operations in a manufacturing environment
- to indicate faulty equipment

FEATURES:

- solid state power supply
- low power consumption (12 watts)
- intensity 2,000,000 candlepower (peak)
- Polycarbonate fresnel lens
- cast zinc alloy housing with a grey epoxy finish for superior corrosion resistance
- designed for intermittent visual signaling as well as longer duration signaling applications
- flash rate - 60 flashes/minute
- flash tube life - minimum 10 million flashes at 60 flashes/minute
- 3/4" conduit entry
- weatherproof



Made in Canada



Applied Strobe Technology Company Limited

INDUSTRIAL STROBE WARNING LIGHTS

8345 Stanley Avenue, Niagara Falls, Ontario, Canada L2E 6X8 905-374-3077, Fax 905-374-6114
U.S. Address: 2315 Whirlpool St., Suite #182, Niagara Falls, NY 14305
e-mail: sales@appliedstrobe.com www.appliedstrobe.com

Temperature Range

-40 C to +85 C

Electrical Ratings

Supply Voltage Range	Frequency	Current Range (avg)	Inrush Current (max)
90 to 130 VAC	50/60Hz	.118 A to .090 A	.250 A
220 to 250 VAC	50/60Hz	.072 A to .055 A	.220 A
10 to 30 VDC	-	.8 A to .4 A	1.30 A
50 to 60 VDC	-	.360 A to .300 A	.820 A
90 to 130VDC	-	.175A to .090 A	.250 A
220 to 250VDC	-	.070A to .055 A	.220 A
15 to 30 VDC	-	.8 A to .4 A	1.30 A

Net Weight: 4.5 lbs

Ordering Information

Model No	Input Voltage
AST-2-90-130-AC	90 - 130 VAC
AST-2-220-250-AC	220 - 250 VAC
AST-2-10-30-DC	10 - 30 VDC
AST-2-90-130-DC	90 - 130 VDC
AST-2-220-250-DC	220 - 250 VDC
AST-2-50-60-DC	50 - 60 VDC

Lens Colors

- AM - Amber Lens
- BL - Blue Lens
- RE - Red Lens
- GR - Green Lens
- CL - Clear Lens

Ordering Example

AST-2-10-30-DC-RE

Replacement Parts

Circuit Board

AST-2 - 90-130-AC -Board	90 - 130 VAC	Circuit Board
AST-2-220-250-AC -Board	220 - 250 VAC	Circuit Board
AST-2 - 10 - 30-DC -Board	10 - 30 VDC	Circuit Board
AST-2 - 90-130-DC -Board	90 - 130 VDC	Circuit Board
AST-2-220-250-DC -Board	220 - 250 VDC	Circuit Board
AST-2 - 50 - 60-DC -Board	50 - 60 VDC	Circuit Board

Flash Tube

AST-FT 3050 Flash Tube

Lenses

AST-2-Lens-RE	Red Lens
AST-2-Lens-AM	Amber Lens
AST-2-Lens-BL	Blue Lens
AST-2-Lens-GR	Green Lens
AST-2-Lens-CL	Clear Lens

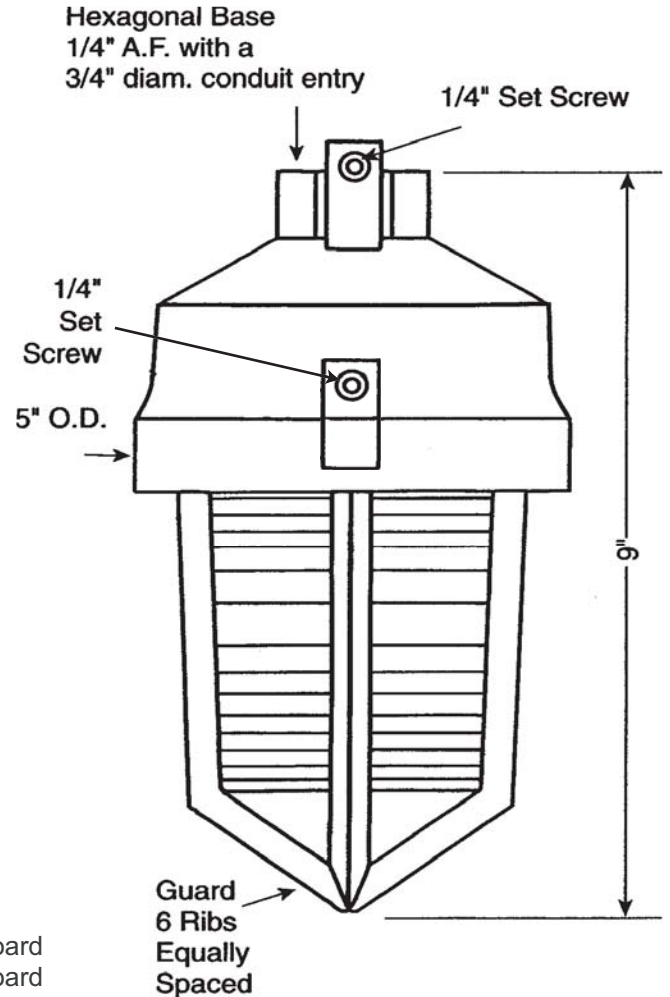

PENDANT MOUNT STROBE